

# TA-1

**Capacidad** Capacity Capacité  
400\* - 500 - 550 - 750 - 1000 - 1100 - 1500 - 1760 kg

  
Certificate  
LOM 07ATEX2006

  
Certificate  
N° E-01.02.C07

**Hasta 4000 divisiones OIML-R60**  
Up to 4000 divisions OIML-R60  
Jusqu'à 4000 divisions OIML-R60

**Totalmente en acero inoxidable**  
Fully stainless steel  
Totalement en acier inoxydable

**Disponible en soporte de acero aleado**  
Measuring element available from alloy steel  
Disponible le support élastique en acier allié

**Estanqueidad IP-68 (EN 60529)**  
Protected against humidity IP-68 (EN 60529)  
Étanchéité IP-68 (EN 60529)

**Sellado hermético, completamente soldada**  
Hermetically sealed, fully welded  
Scellement hermétique, complètement soudé

**Disponible en versión ATEX (opcional)**  
 **II 1GD Ex ia IIC T6 IP67 T85°C**  
Available in ATEX version (optional)  
Disponible version ATEX (optionnel)

## Características técnicas Technical Data Caractéristiques Techniques

Clase de precisión Accuracy class Classe de précision	C3-C4
Sensibilidad Rated output Sensibilité	$2 \pm 0.1\%$ mV/V
Vmin Vmin Vmin	Emax/15000
Tensión de alimentación Excitation Voltage Tension d'alimentation	5÷15 V
Resistencia de entrada Input Resistance Résistance d'entrée	$350 \pm 3$
Resistencia de salida Output resistance Résistance de sortie	$350 \pm 3$
Margen de temperatura compensado Temperature limits OIML R60 Marge de température compensée	-10° C / +40° C
Resistencia de aislamiento Insulation resistance Résistance d'isolement	> 5000 M

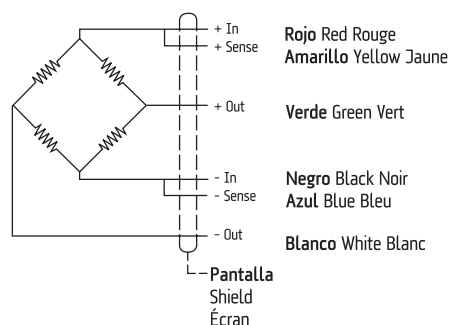
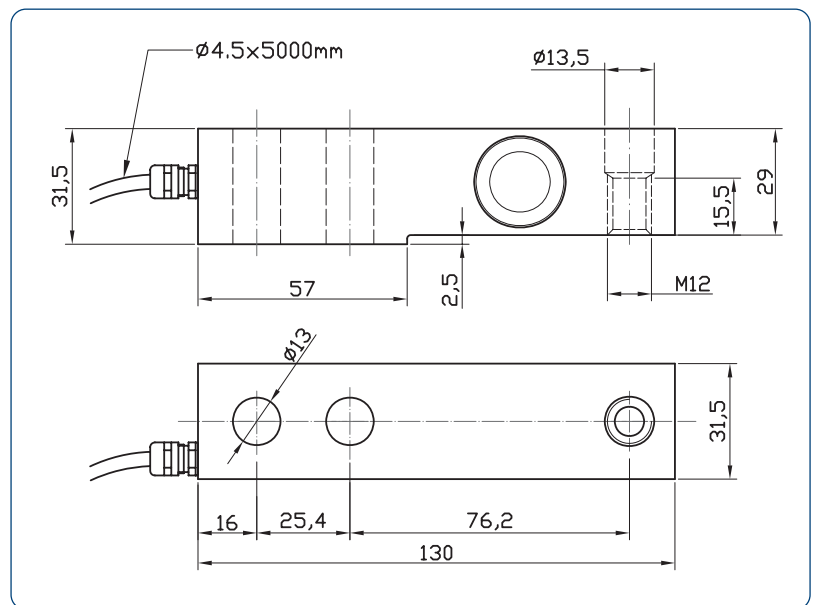

## Conexión Connections Connexions

Sense opcional  
Optional Sense  
Sense optionnel



Tel.: 34 93 780 44 99  
Fax: 34 93 780 39 72  
[www.sensocar.com](http://www.sensocar.com)  
[comercial@sensocar.com](mailto:comercial@sensocar.com)

# TA-1 Accesorios - Accessories - Accessoires

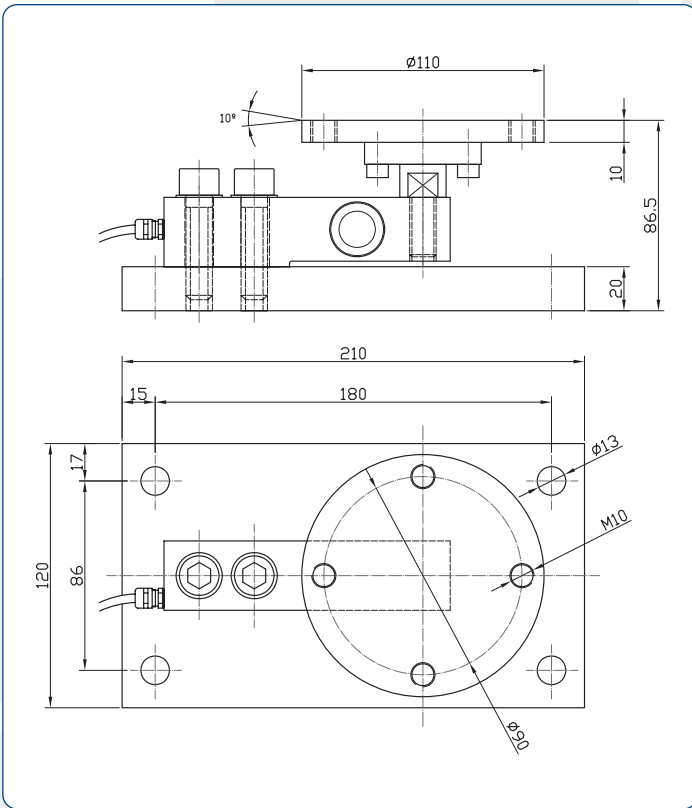

**Sistema antivuelco**  
 Tank weigh module  
 Systeme Anti-renversement

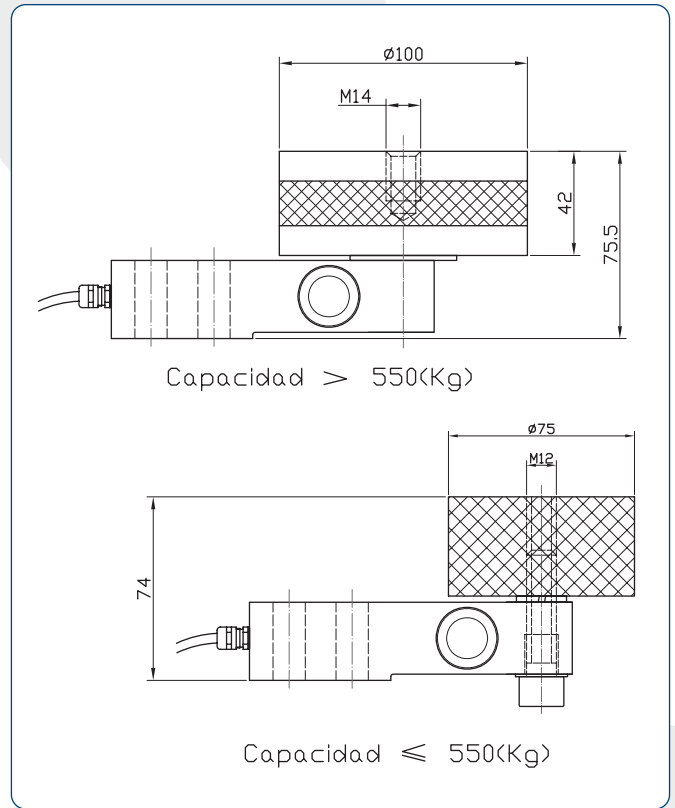

**Silent Block**  
 Silent BLock  
 Silent BLock

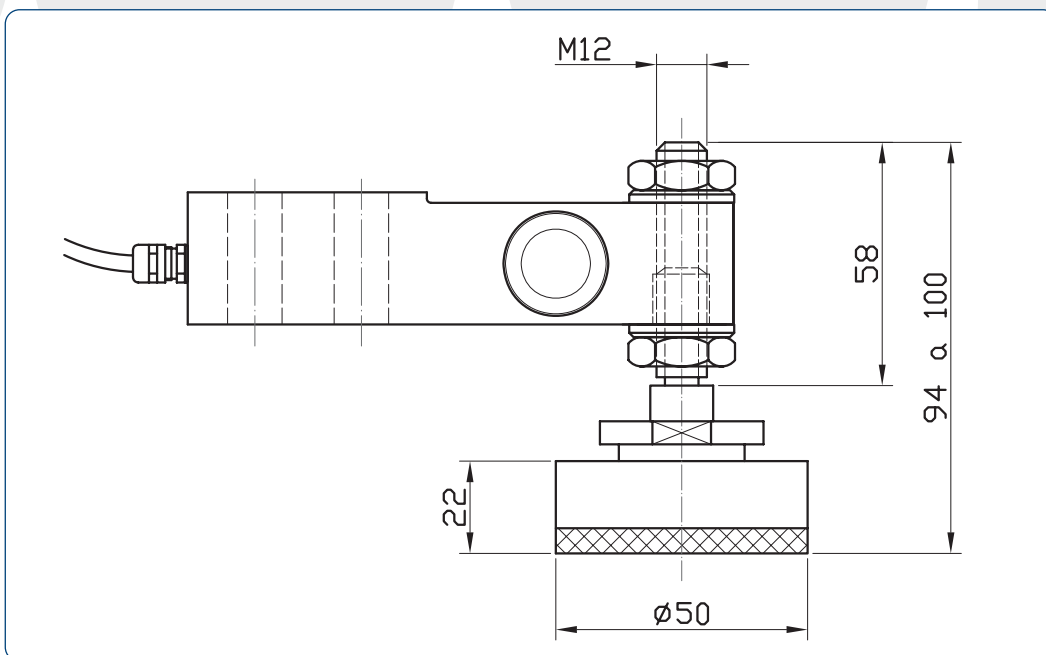

**Pata autocentrante de altura regulable con bola**  
 Load foot with adjustable height  
 Pied autocentrante de hauteur réglable à bille